

Eagle Football Playbook

The following pages contain offensive formations and plays that we will be using this year. It is key for all players to understand the hole numbering scheme. Any player who has been practicing in the offensive back field needs to have a full understanding of the formations we use as well as our back numbering system. Interior linemen are considered interchangeable and as such are expected to understand blocking assignments for all line positions on all plays (Guards, Tackles, Centers -- the goal is for everyone to remain engaged in their block for at least 5 seconds). We will begin with two formations and four plays:

- 24 (Dive) -- the opposite of which is a 33 (Dive)
- 34 (Power) -- the opposite side play equivalent is a 23 (Power)
- 36 (Cross) -- with its 25 (Cross) counterpart
- 18 (Sweep) -- where the 17 (Sweep) goes in the other direction

All of our plays can be run out of either a Slot Right or Slot Left formation (although a 36 will usually be run out of a Slot Right and 25 works best with a Slot Left). As we move through the season and become proficient with these plays, we will add progressions to each play ie. 24 Keeper or 18 Pass. We will also be adding a few gimmick plays such as the 10 (quarterback sneak) which have already used in practice.

Slot Right Formation

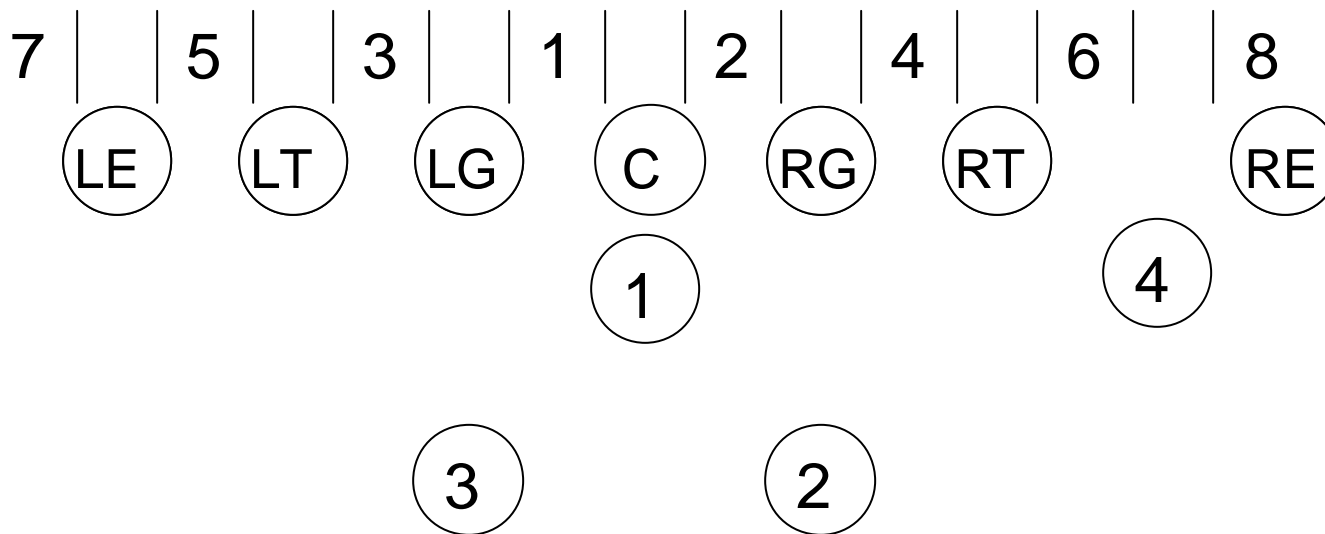

Slot Left Formation

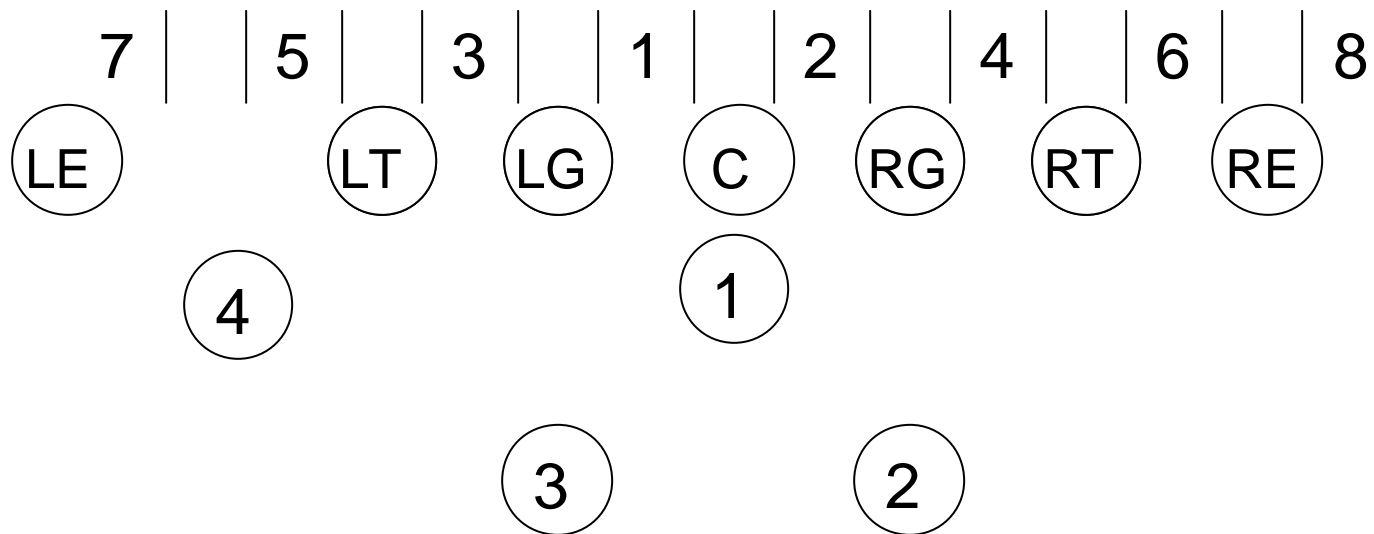

Slot Right 24 (Dive)

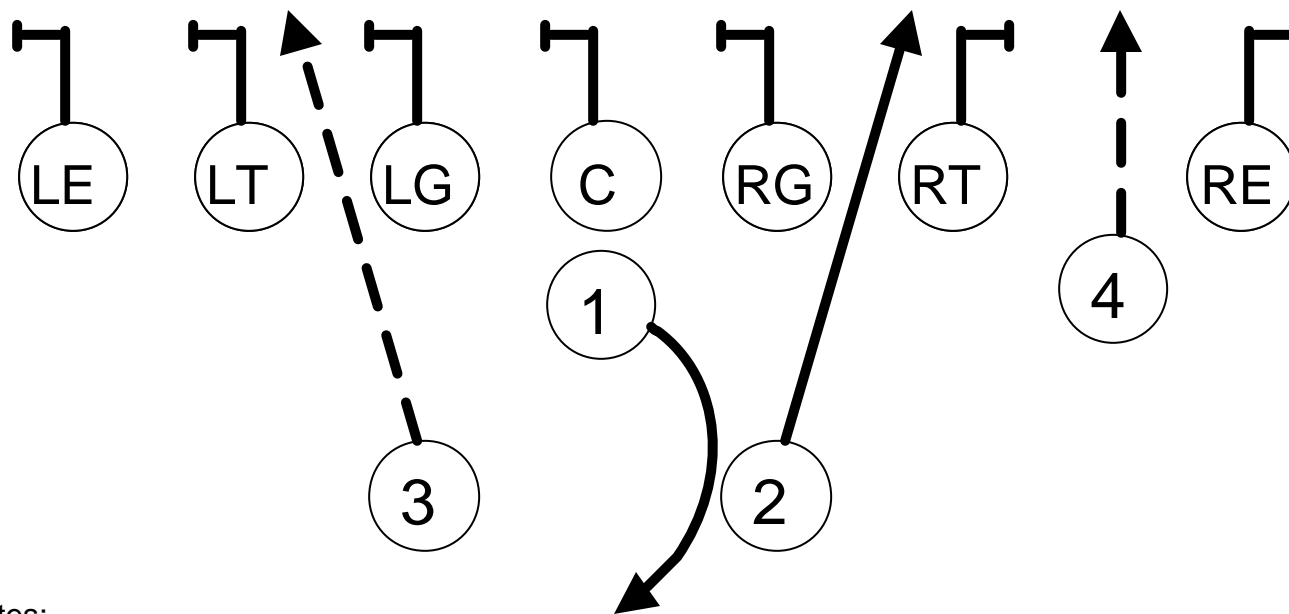

Notes:

- Line & 4 - Block head-up to outside away from the play hole - hold block for full 5 seconds
- Ends - Block head-up to outside for 2 seconds and release
- 1 - start right - hand off to 2 while rolling out to left (right while facing back) with left hand hip
- 2 - through 4 hole with ball - do **not wait** for ball
- 3 - through 3 hole - fake carrying the ball

Slot Right 33 (Dive)

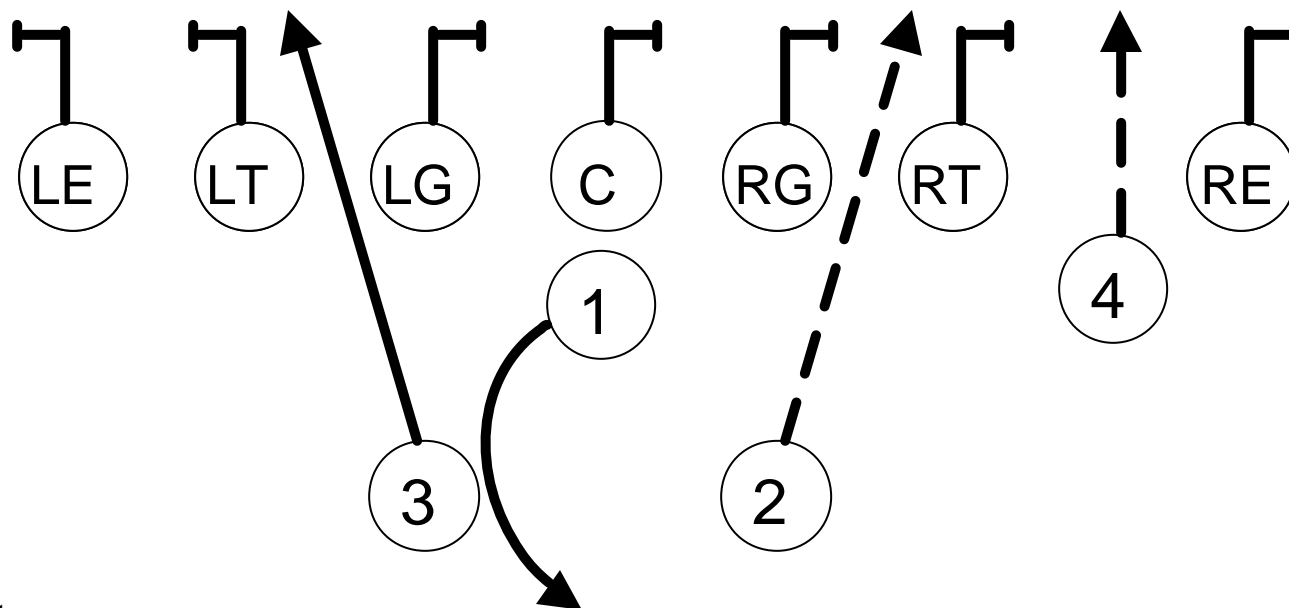

Notes:

- Line & 4 - Block head-up to outside away from the play hole - hold block for full 5 seconds
- Ends - Block head-up to outside for 2 seconds and release
- 1 - start left - hand off to 3 while rolling out to right (left while facing back) with right hand hip
- 2 - through 4 hole - fake carrying the ball
- 3 - through 3 hole with ball - do **not wait** for ball

Slot Right 23 (Power)

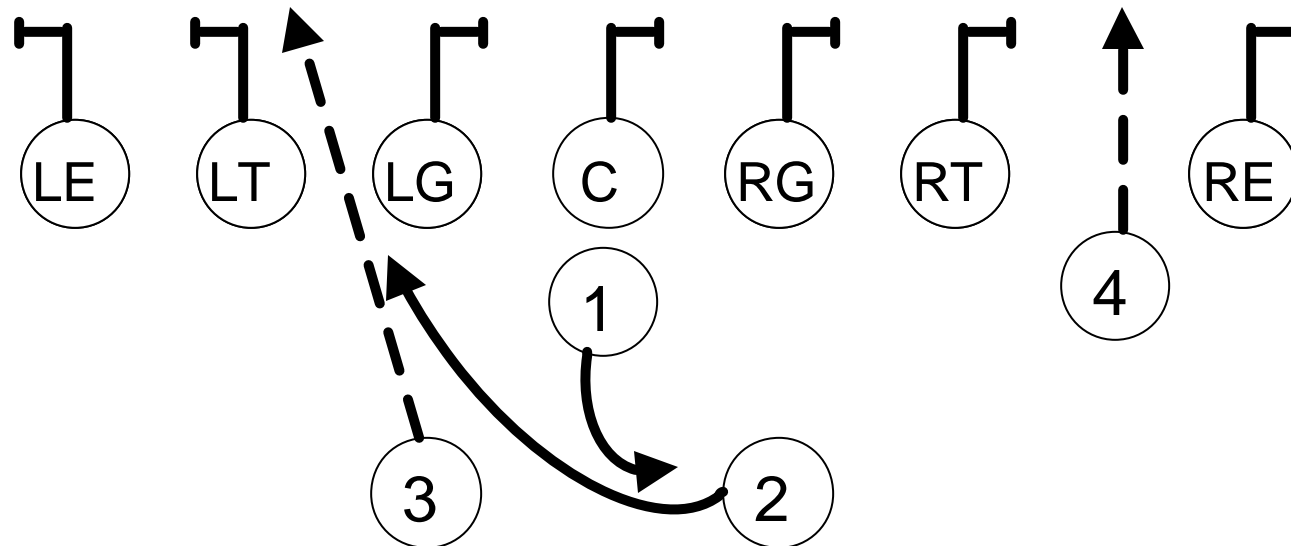

Notes:

- Line & 4 - Block head-up to outside away from the play hole - hold block for full 5 seconds
- Ends - Block head-up to outside for 2 seconds and release
- 1 - start left - hand off to 2 while rolling out to right (left while facing back) with right hand hip
- 2 - through 3 hole behind 3 back with ball - do **not wait** for ball
- 3 - through 3 hole - **be quick** - blocking first person in the hole - expect to block the linebacker

Slot Right 36 (Cross)

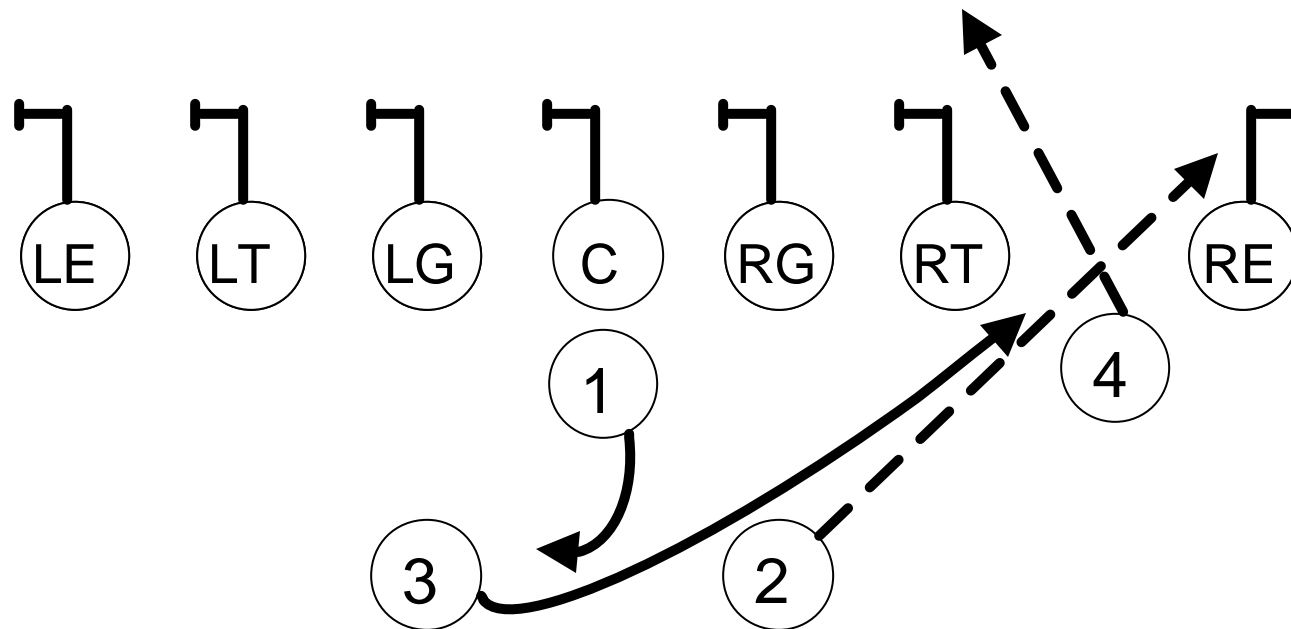

Notes:

- Line - Block head-up to outside away from the play hole - hold block for full 5 seconds
- Ends - Block head-up to outside for 2 seconds and release
- 1 - start right - hand off to 3 while rolling out to left (right while facing back) with left hand hip
- 2 - through 6 hole - **be quick** - blocking first person in the hole - expect to block the DE
- 3 - through 6 hole behind 2 back with ball - do **not wait** for ball
- 4 - Blast back on linebacker (LB) - hold block for full 5 seconds

Slot Left 25 (Cross)

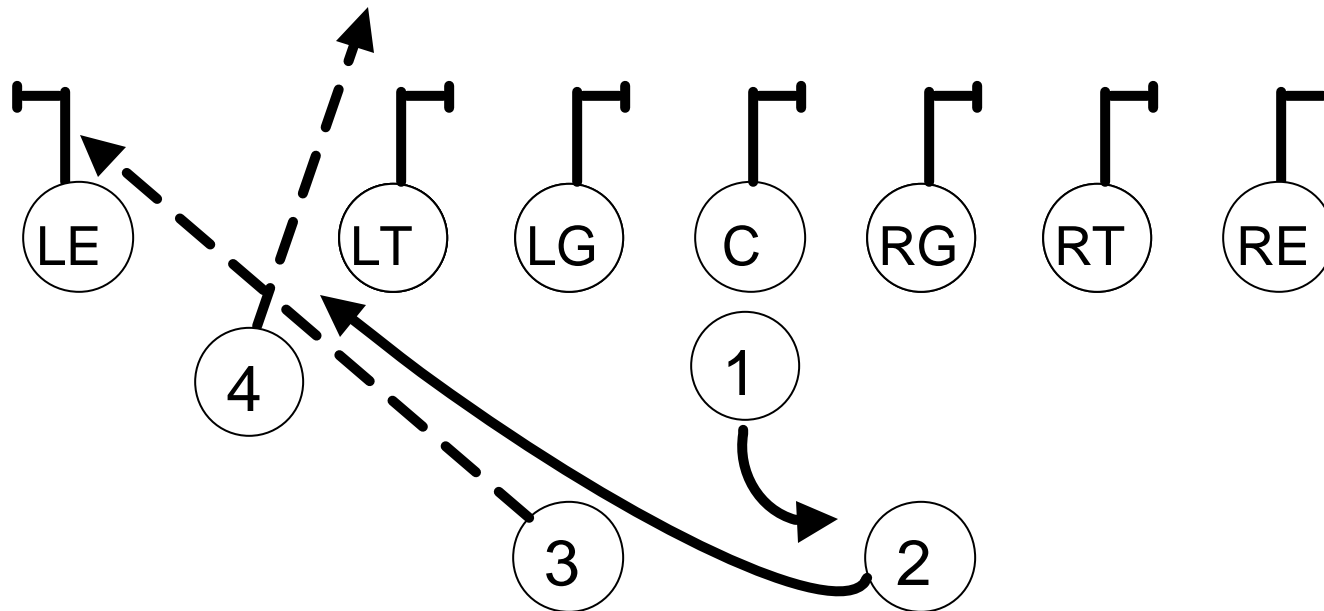

Notes:

- Line - Block head-up to outside away from the play hole - hold block for full 5 seconds
- Ends - Block head-up to outside for 2 seconds and release
- 1 - start left - hand off to 2 while rolling out to right (left while facing back) with right hand hip
- 2 - through 5 hole behind 2 back with ball - do **not wait** for ball
- 3 - through 5 hole - **be quick** - blocking first person in the hole - expect to block the DE
- 4 - Blast back on linebacker (LB) - hold block for full 5 seconds

Slot Right 18 (Sweep)

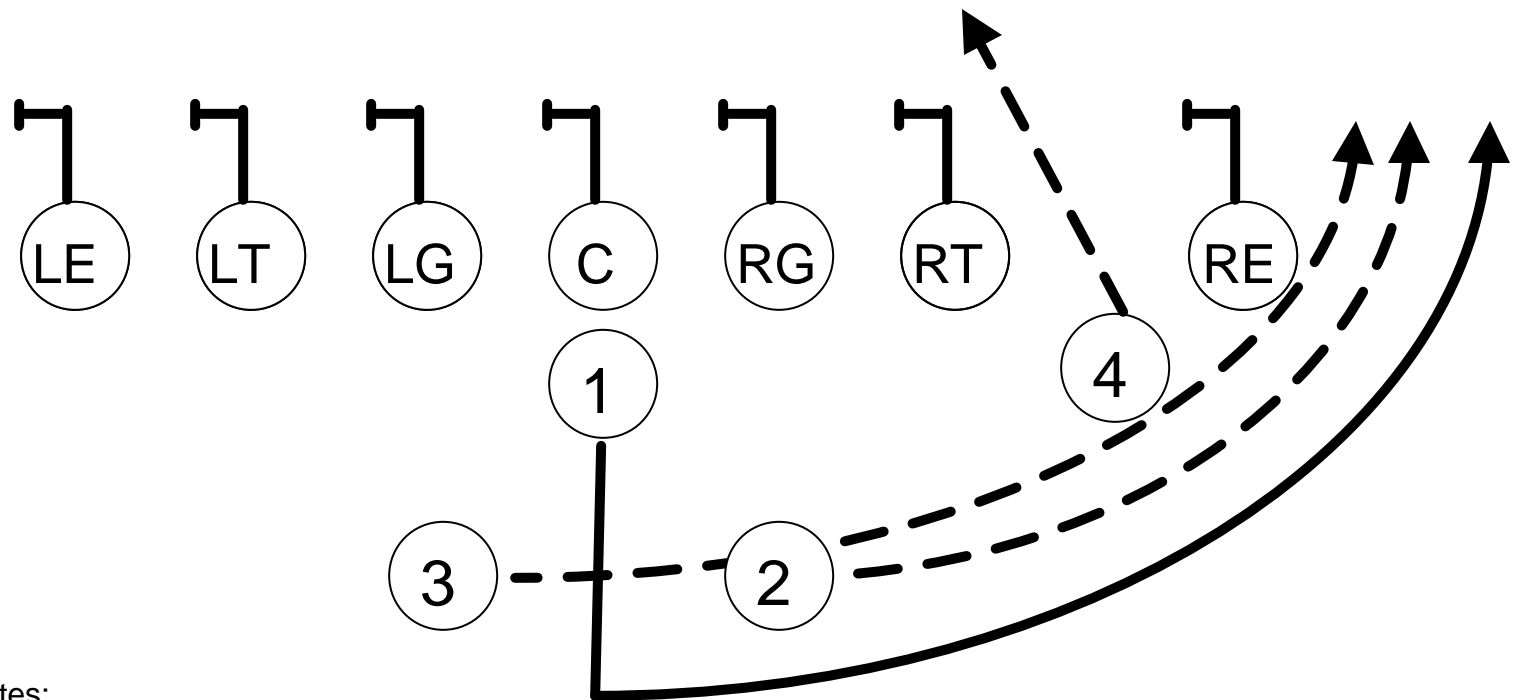

Notes:

- Line - Block head-up to outside away from the play hole - hold block for full 5 seconds
- Ends - Block head-up to outside for 2 seconds and release
- 1 - spin left and move behind 3 moving to the right - keep ball around right end
- 2&3 - around 8 hole (side) - **be quick** - blocking first person you see - expect to block DE & CB
- 4 - Blast back on linebacker (LB) - hold block for full 5 seconds